

Dairy Tales Coloring Book

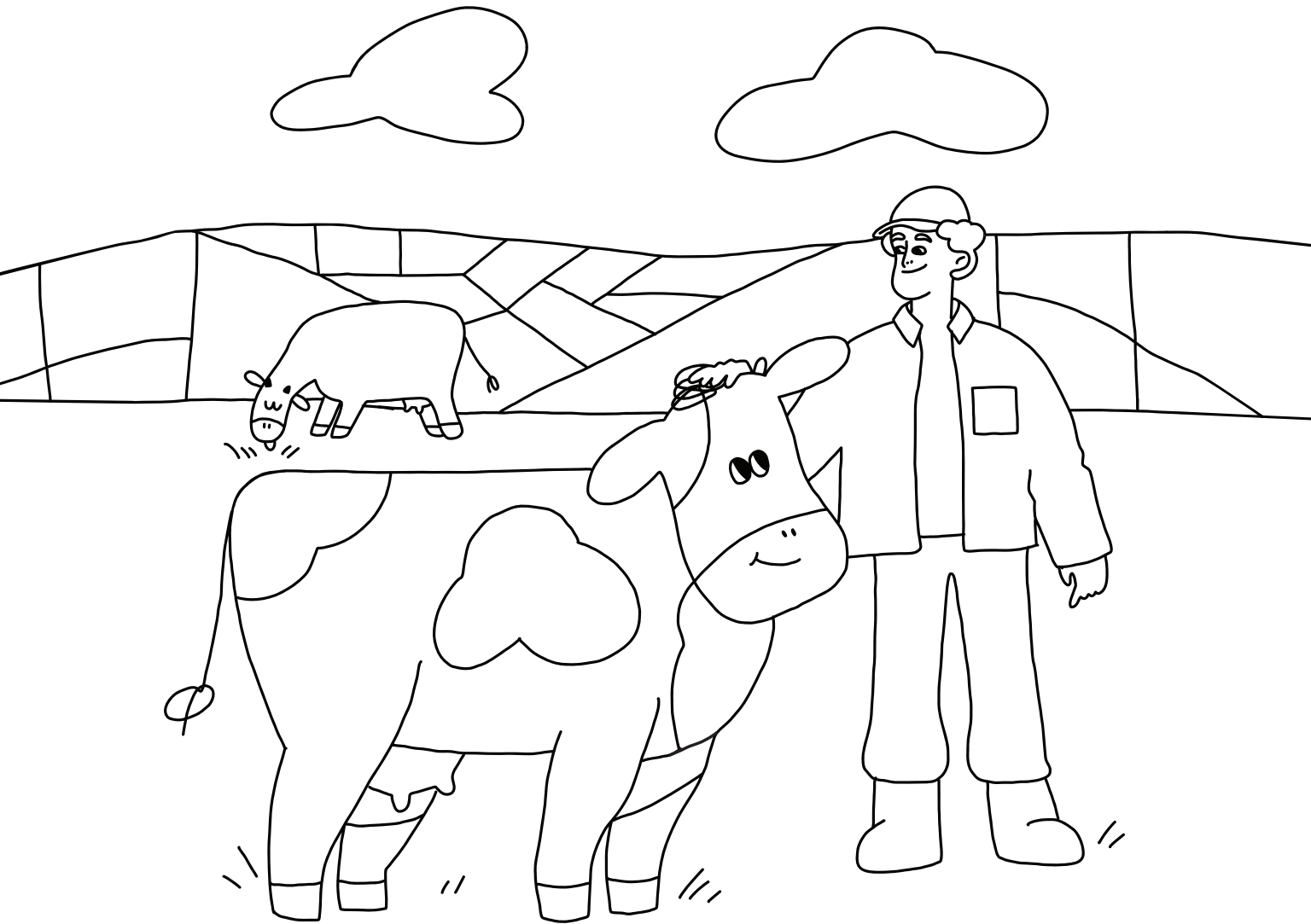

DAIRY FARMERS OF WASHINGTON

Cow Comfort



Cassy the cow and her farmer agree
when healthy, her milk is as good as can be.



When the vet comes to visit,
she heeds their advice.

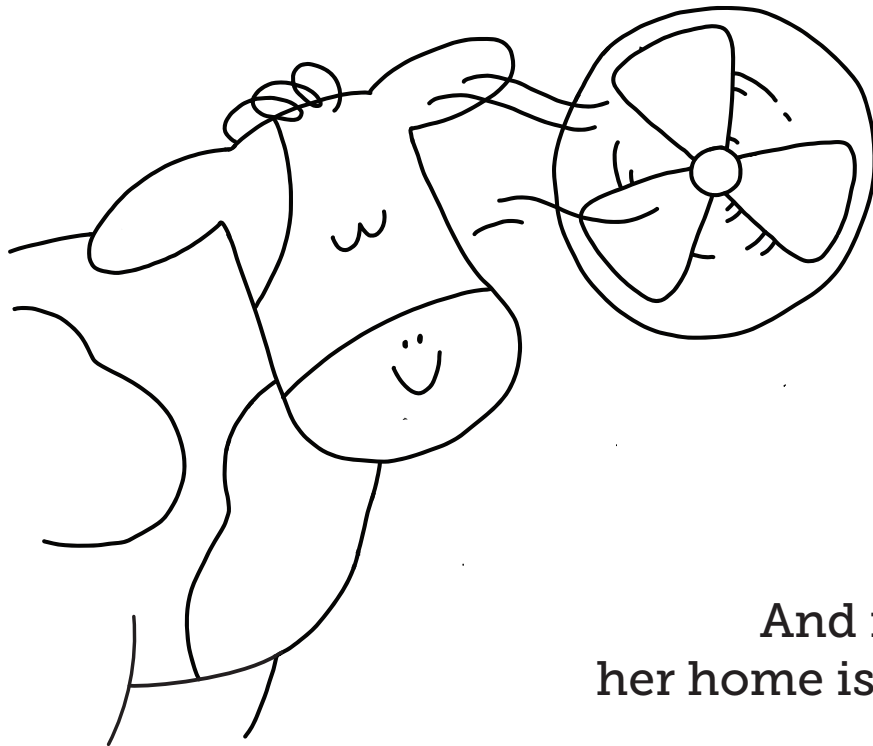

And farmers ensure
her home is cozy and nice.

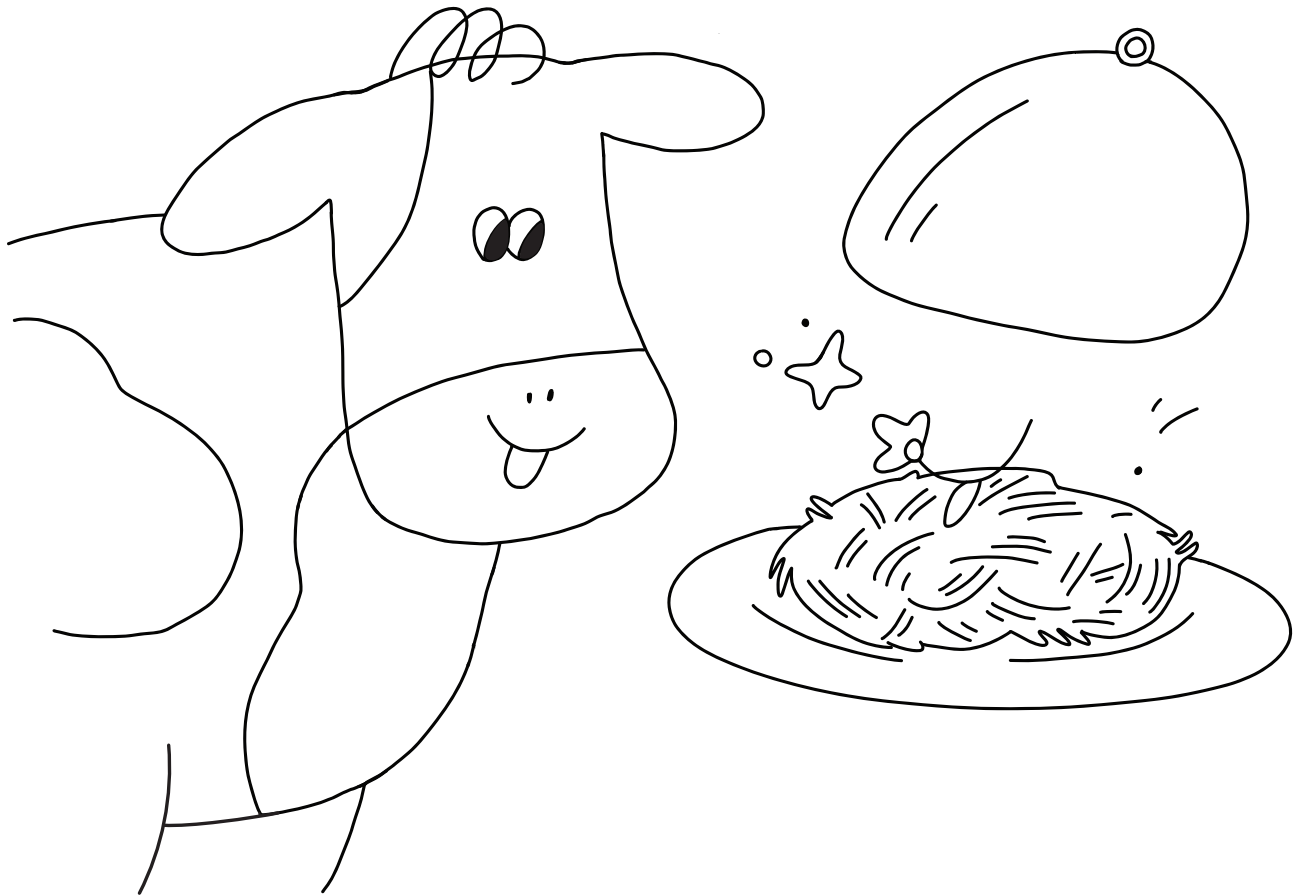

The nutritionist puts thought into all that she eats:
nutrient-rich food and her favorite treats.

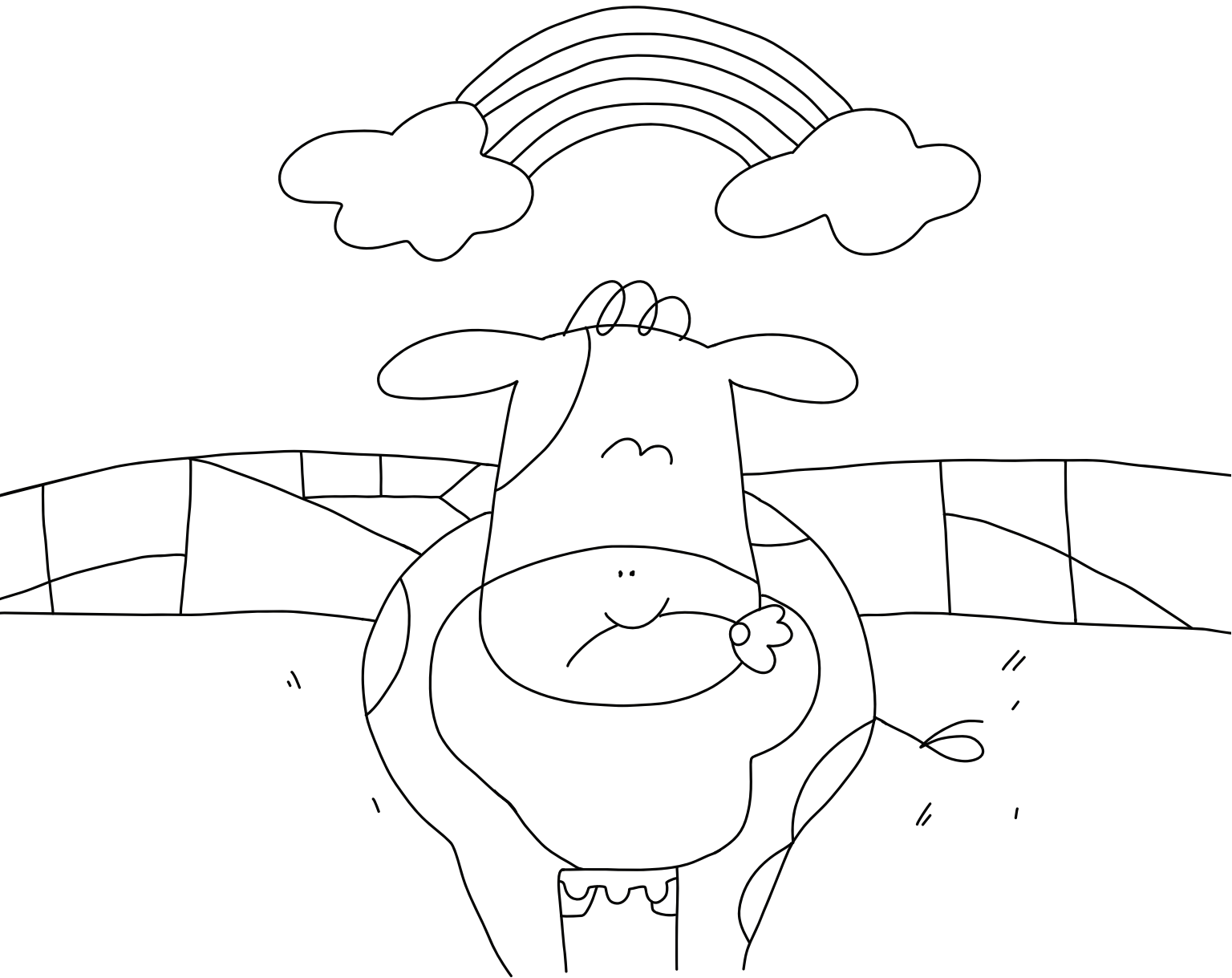

When happy and healthy, and her conditions ideal,
Cassy makes milk that's as good as she feels.

Water Conservation

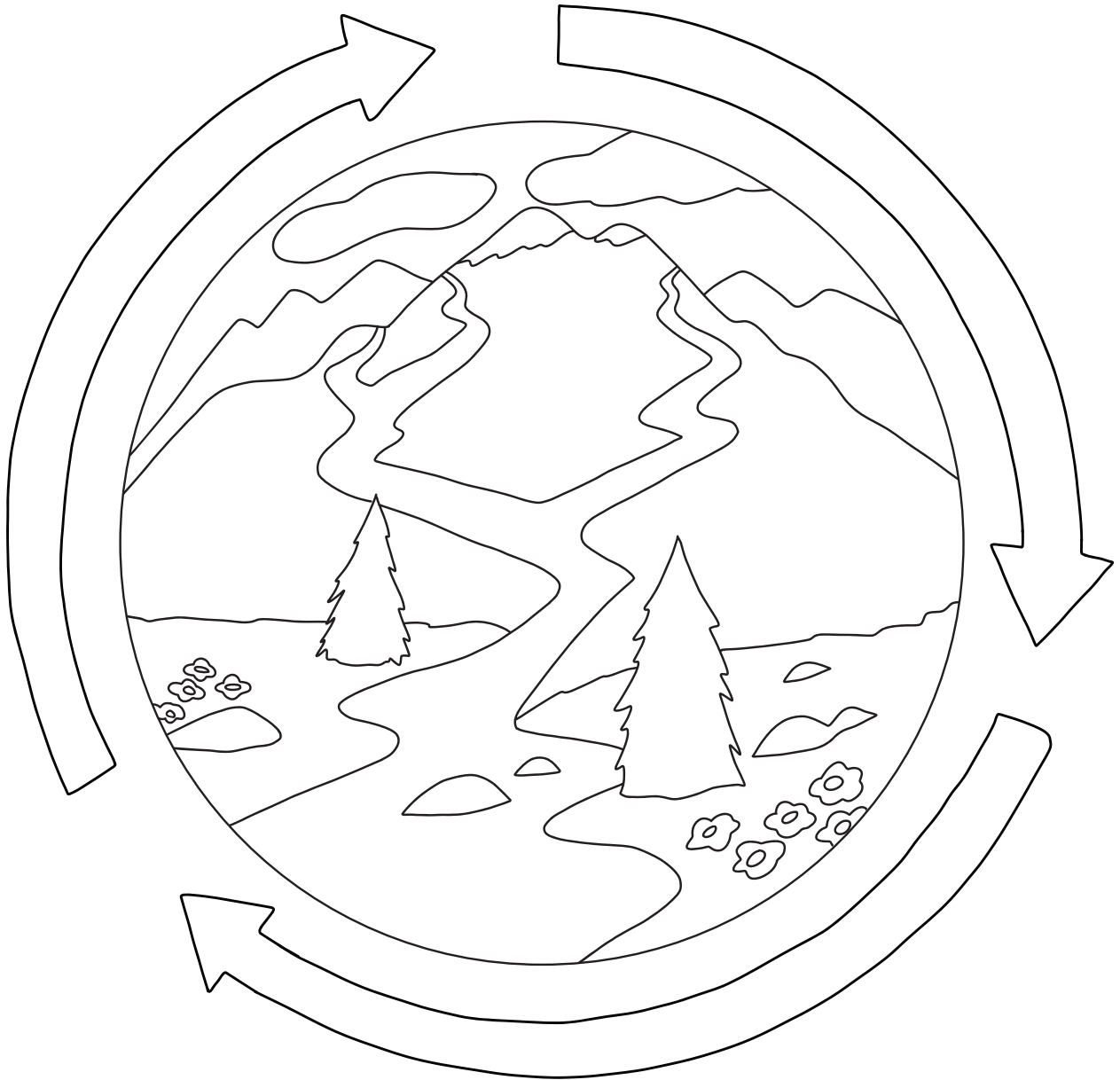

Without water life would be tough.
We must share and conserve it so we all have enough.

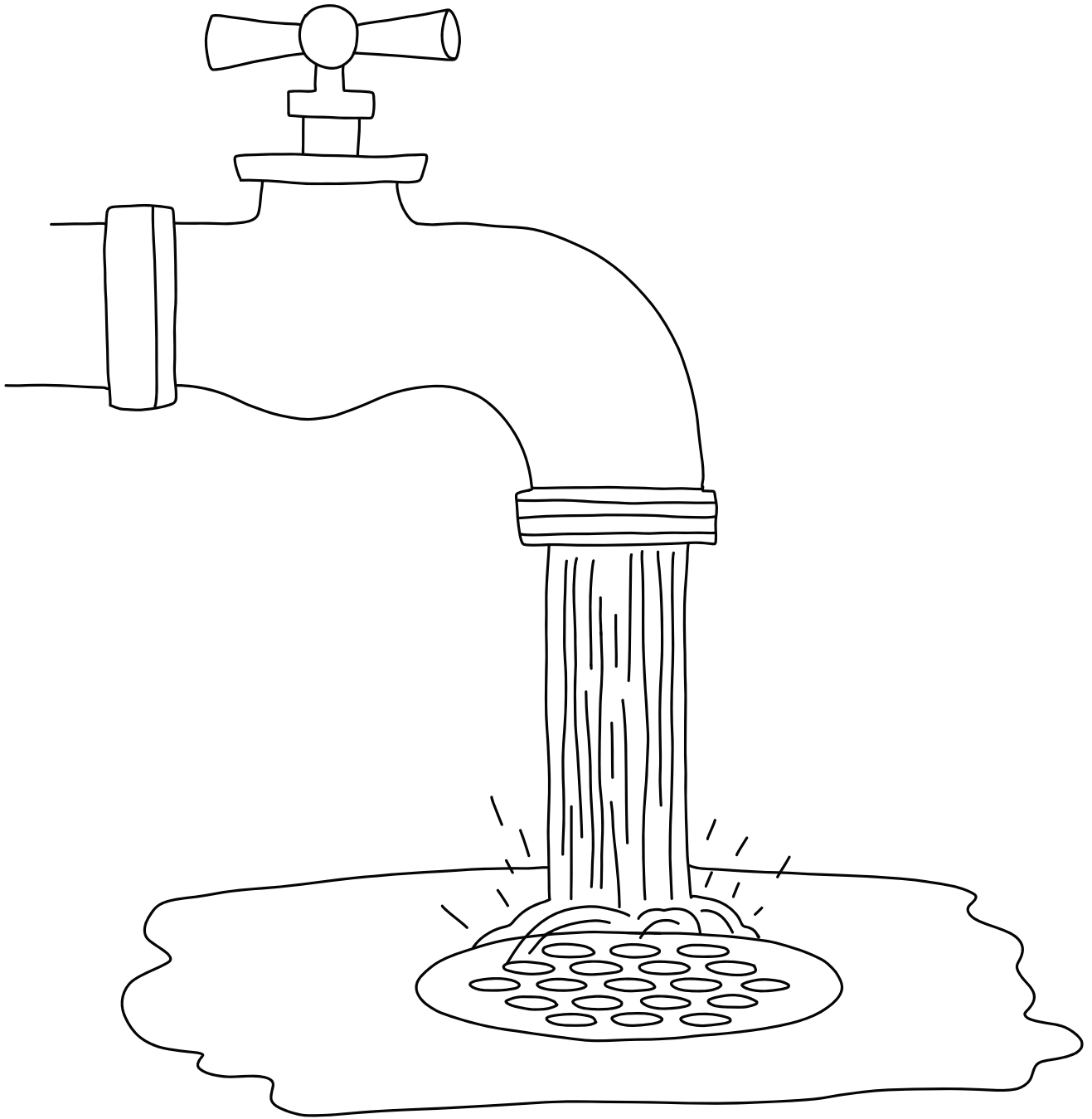

When people use water, it often drains away,

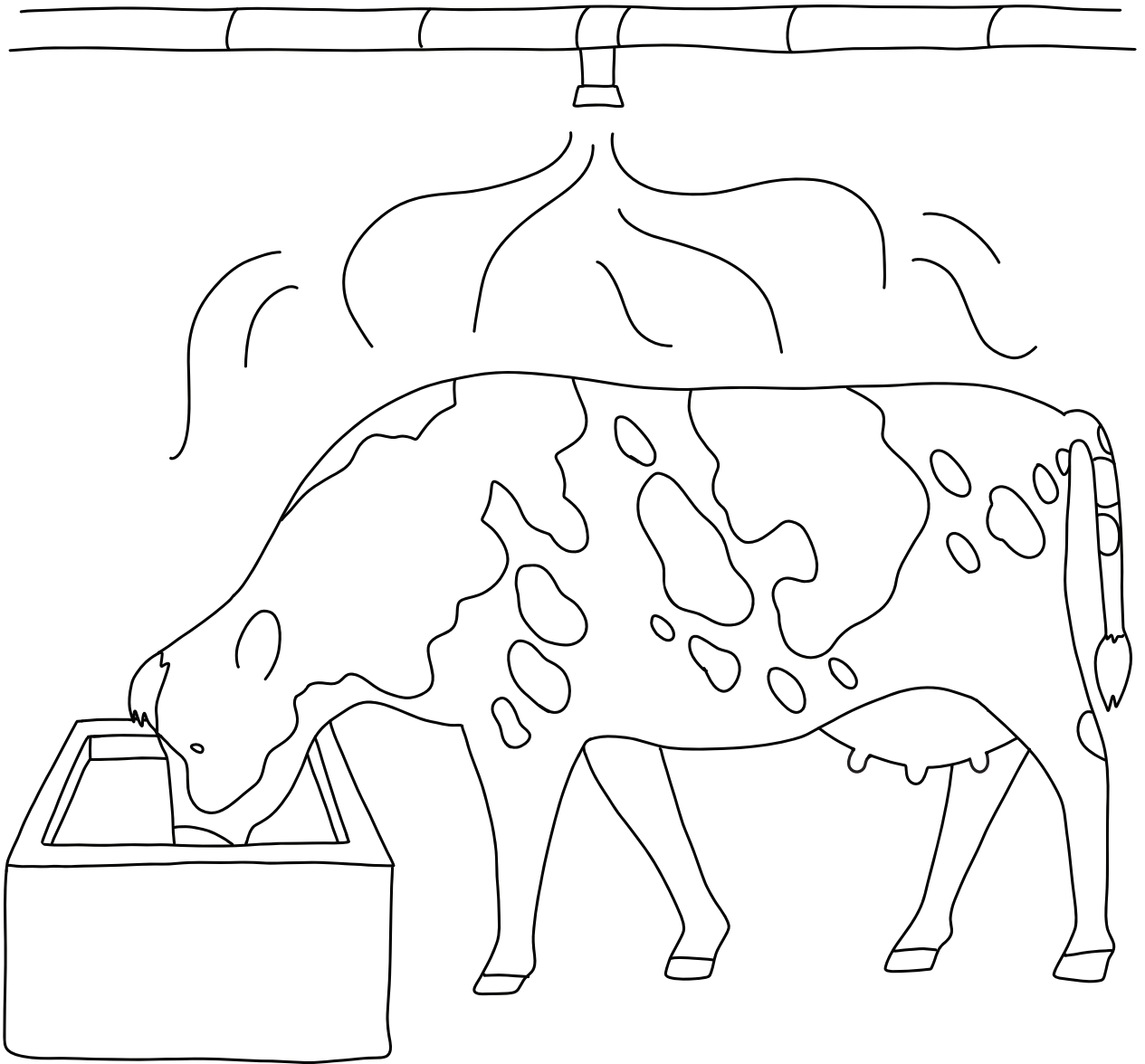

but water on the farm
is recycled in many different ways.

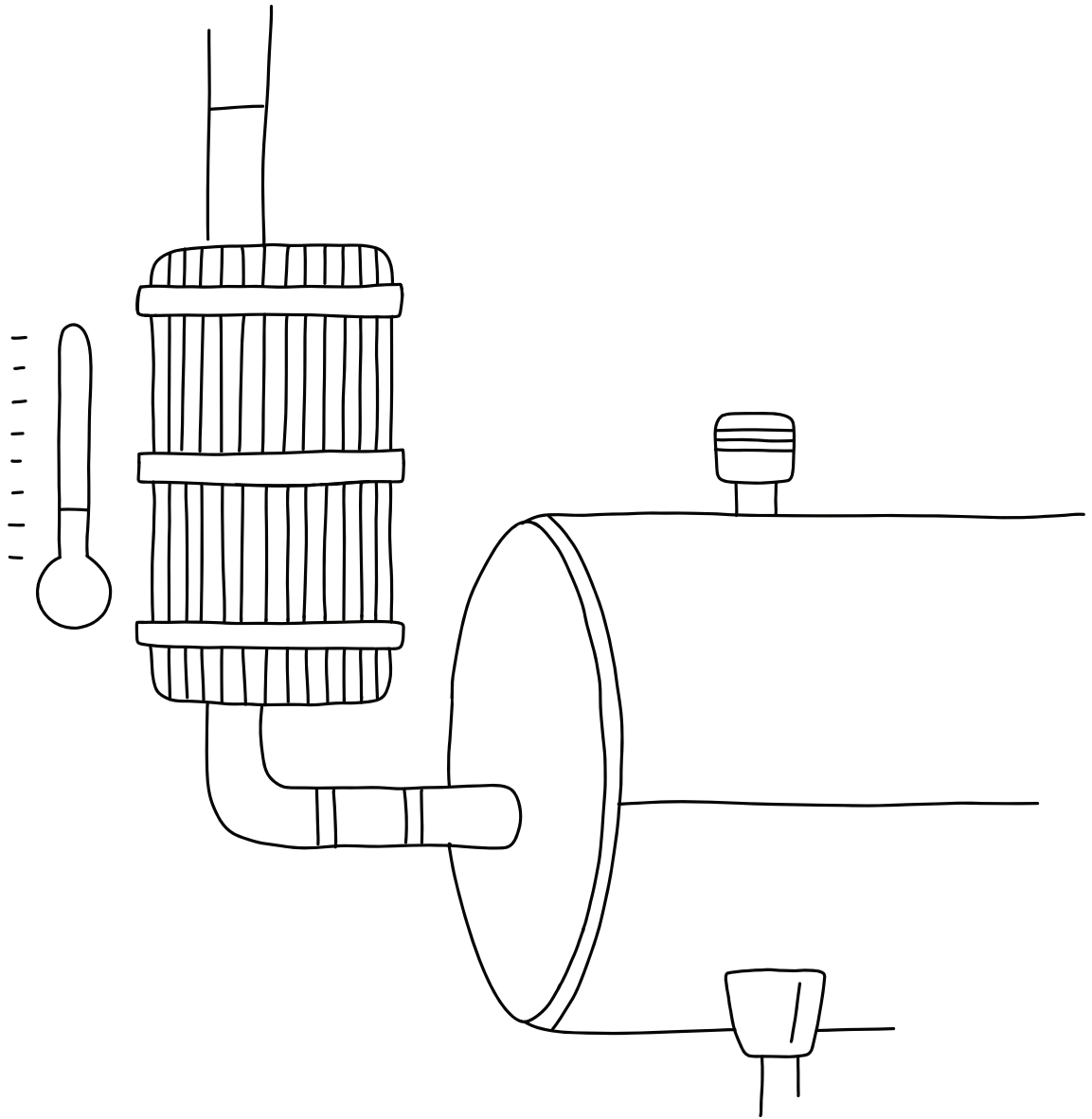

Clean water cools milk on its way to be stored.

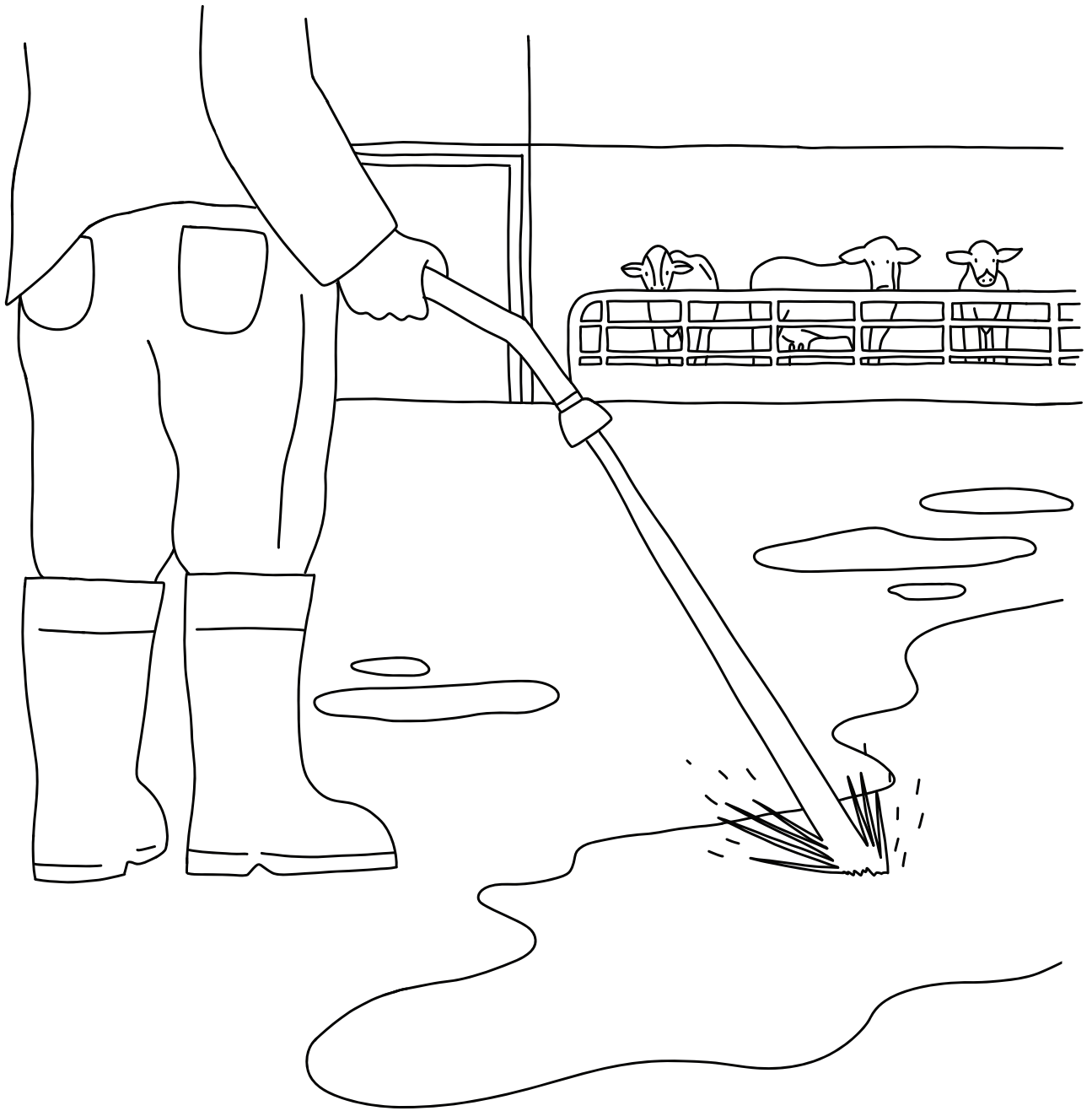

And the many ways it comforts cows can't be ignored.
It's also reused to clean the floors and the stalls.

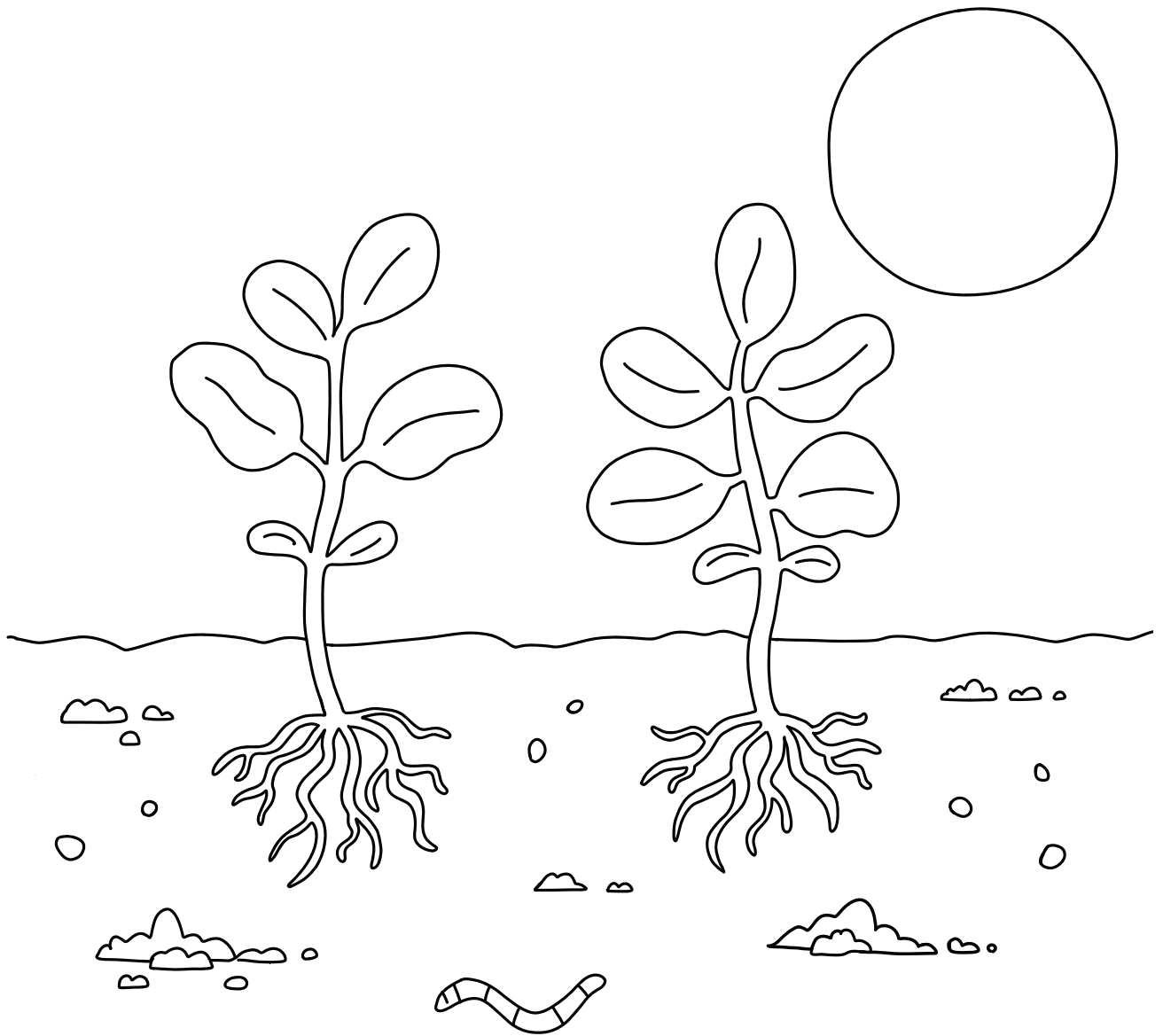

Before fertilizing the fields so our crops grow tall.

The Power of Poop



Just a happy cow chewing her cud.



Then plop, a poop lands with a splud!

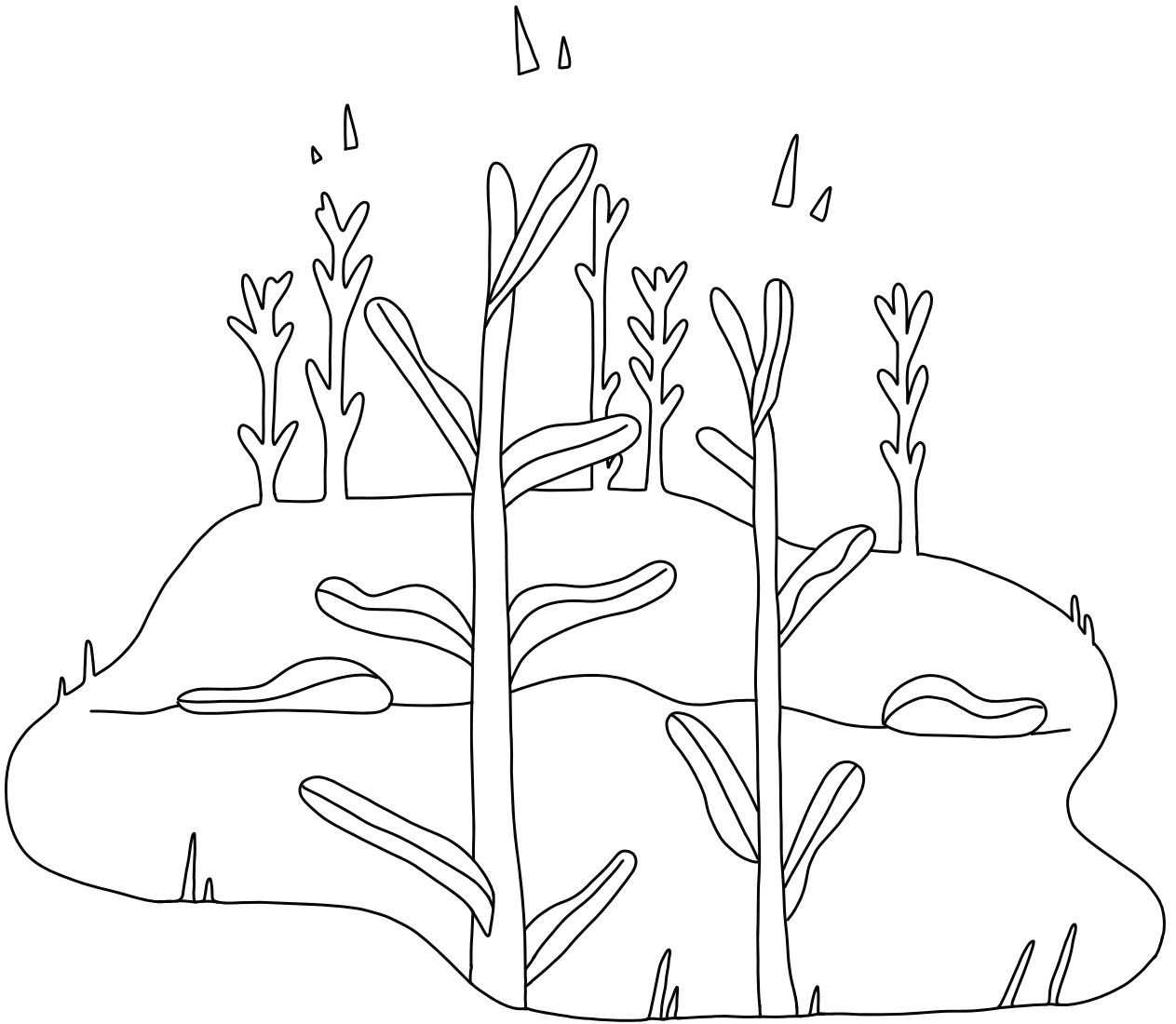

It won't be wasted though, off it will go to make compost or fertilizer, to help the crops grow.

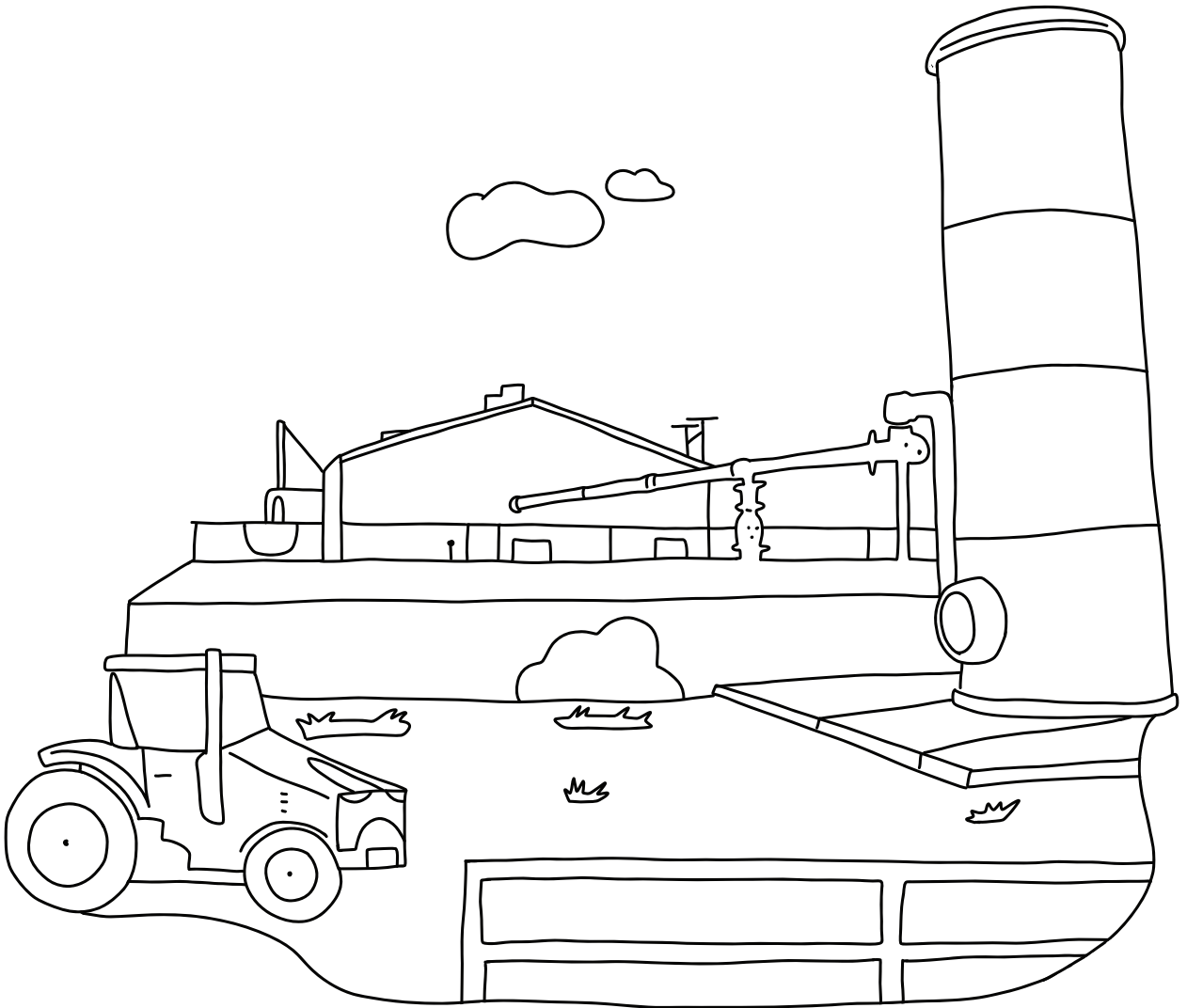

To the farm's digester, the waste will embark,

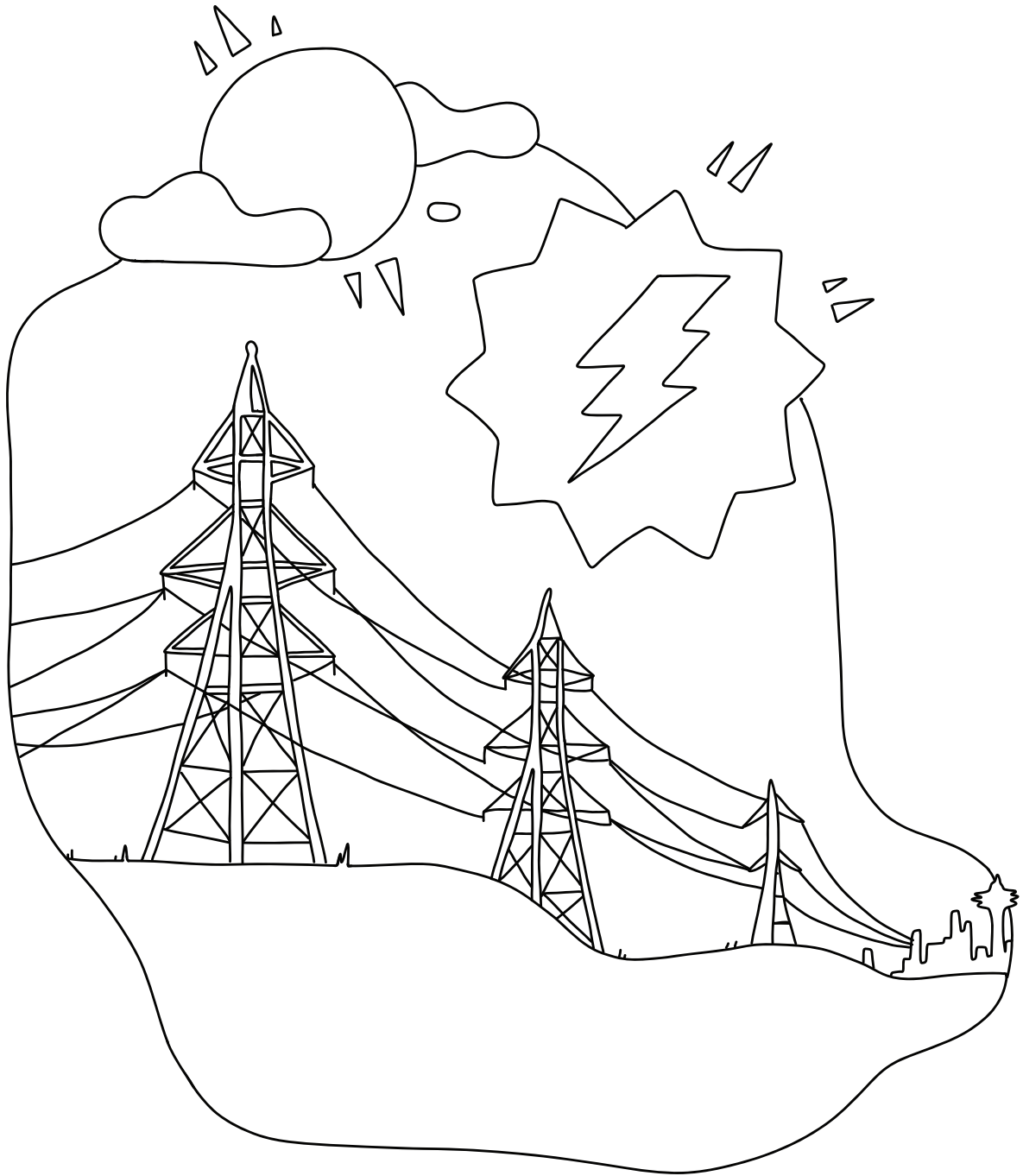

methane to clean energy, a renewable spark.



Our farms have so many innovations under way.
Because we all share this world
and want its beauty to stay.



WADAIRY.ORG